

HTM400 AC Drilling Motor Maintenance Manual

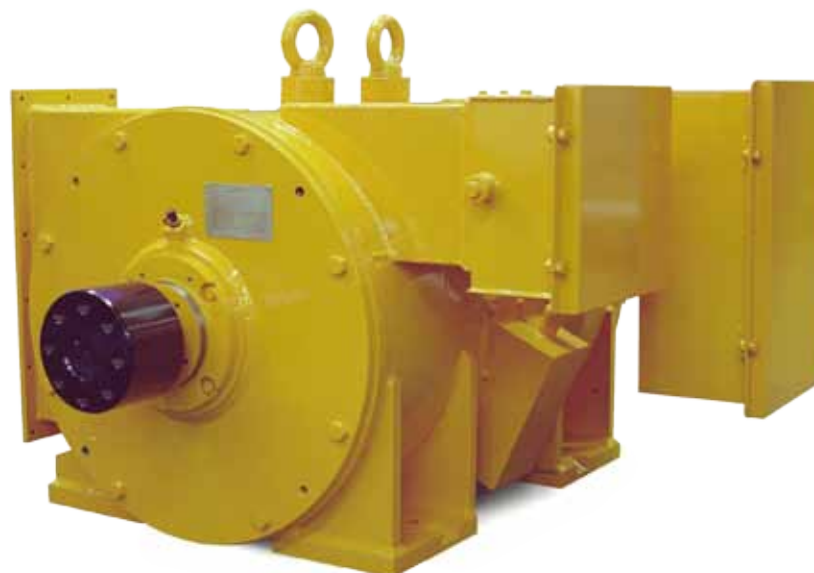

Hitachi, Ltd.

Tokyo Japan

JOLIET

Engineered Drilling Motors

Joliet Equipment Corporation

RECORD OF CHANGES

Change No.	Date	Title and/or brief description	Remarks

TABLE OF CONTENTS

Section		Title	Page No.
I		INTRODUCTION	I - 1
	1.1	Important Notice Regarding Contents and Use of This Manual	I - 1
	1.2	Safety Instructions	I - 2
II		TECHNICAL INFORMATION	II - 1
	2.1	Technical Data and Specification	II - 1
	2.2	Construction of Motor	II - 2
		2.2.1 General Construction	II - 2
		2.2.2 Rotor	II - 3
		2.2.3 Bearings	II - 3
	2.3	Testing and Quality Assurance, Warranty and Service	II - 4
III		RECEIVING, HANDLING AND STORAGE	
	3.1	Receiving	III - 1
	3.2	Handling	III - 1
	3.3	Unpacking	III - 1
	3.4	Storage	III - 2
IV		INSTALLATION	IV - 1
	4.1	Preparation of Installation of the Motor	IV - 1
		4.1.1 Method of Foundation and Types of Foundation Bolts	IV - 1
		4.1.2 Installation	IV - 1
		4.1.3 Mounting Procedure of Motor Base	IV - 2
		4.1.4 Tolerance for Motor Installation	IV - 3
	4.2	Coupling	IV - 3
		4.2.1 Alignment	IV - 3
		4.2.2 Tolerance for Motor Alignment	IV - 4
	4.3	Tightening Torques of Bolts and Nuts	IV - 4
	4.4	Connection to Power Cable	IV - 5
	4.5	Recommendation of Lubricant	IV - 5
		4.5.1 Continuous Operation	IV - 5
		4.5.2 Grease	IV - 6
V		OPERATION	V - 1
	5.1	Inspection during Initial Commissioning	V - 1
		5.1.1 Inspection before Trial Start	V - 1
		5.1.2 Load conditions for Trial Start	V - 1
		5.1.3 Inspection during Motor Running	V - 2
		5.1.4 Direction of Rotation	V - 2
		5.1.5 Limits of Starting Frequency	V - 2
	5.2	Operation	V - 2
		5.2.1 Limits of variation in Voltage, Current and Frequency	V - 2
		5.2.2 Vibration and Noise	V - 3
		5.2.2.1 Vibration	V - 3
		5.2.2.2 Noise	V - 4
		5.2.3 Recommended Setting Values	V - 4

Section		Title	Page No.
VI		MAINTENANCE	VI - 1
	6.1	Periodical Inspection	VI - 1
		6.1.1 Inspection Points	VI - 1
		6.1.2 Insulation Resistance	VI - 2
		6.1.3 High Potential Test	VI - 2
	6.2	Troubleshooting	VI - 3
	6.3	Spare Parts	VI - 8
	6.4	Lifting and Disassembling	VI - 8
	6.5	Spare Parts List	VI - 8
	6.6	Consumables	VI - 9
VII		DISASSEMBLY AND ASSEMBLY	VII - 1
	7.1	Caution to be Observed during Disassembly and Assembly	VII - 1
	7.2	Removal from the Driven System	VII - 1
	7.3	Disassembly of Three Phase Induction Motor	VII - 2
	7.4	Assembly of Three Phase Induction Motor	VII - 4
	7.5	List of Figures	VII - 5

SECTION I

INTRODUCTION

1.1 IMPORTANT NOTICE REGARDING CONTENTS AND USE OF THIS MANUAL

- **Read this manual carefully to understand how to install, operate and maintain the equipment correctly.** Failure to do so could result in injuries to personnel or damages to equipment.
- **Maintain this manual and review frequently for continued safe operation.**
- **Only properly trained and qualified personnel should use this manual.** This manual is not intended to be a primer. It has been prepared on the understanding that it will be read and used by customer's personnel who have received indoctrination in system operation and maintenance under technical guidance and/or appropriate training.
- **This manual is not a complete textbook.** A manual of this kind cannot contain complete information regarding all aspects of the equipment and its uses. It does not provide instruction or information regarding every contingency that could arise during installation, operation and maintenance. Any questions that arise which are not clearly covered by this manual should be referred to Hitachi, Ltd.
- **This manual is intended only for a specific purpose.** The information contained in this manual is intended only for the use of the customer and only in connection with the specific application for which the customer has informed Hitachi, Ltd., that the equipment was purchased. Use by any other person or for any other purpose is not authorized and as to any such unauthorized use, Hitachi, Ltd. assumes no responsibility and makes no representation whatsoever.
- **This manual is not a Warranty or a Contract Document.** The only undertakings of Hitachi, Ltd. with respect to the equipment described or the information contained in this manual are contained in the Sales Contract between Hitachi, Ltd. and the customer. Nothing contained in this manual is to be construed as in any way, changing or enlarging the undertakings of Hitachi, Ltd.
- **This manual involves PROPRIETARY INFORMATION of Hitachi, Ltd. and all rights regarding the same are expressly reserved.** It is submitted under a confidential relationship for a specific purpose and the recipient, by accepting this manual, assumes custody and control of it and agrees to the following :
 - ⇒ that this manual shall not be used, copied or reproduced in whole or in part, nor its contents revealed in any manner to any person except to meet the purpose for which it was delivered, and;
 - ⇒ that any information contained herein shall not be incorporated in other documents.
- **The contents of this manual may be revised without prior notice.**

All Rights Reserved, Copyright © 2010, Hitachi, Ltd.
Printed in Japan

1.2 SAFETY INSTRUCTIONS

(a) IMPORTANT INFORMATION

Carefully read all safety instructions in this manual. WARNING and CAUTION notes are intended to emphasize critical and important information.

The definition of the symbols:



DANGER TO PERSONNEL

Warning notes indicate any condition or practice which if not strictly observed, could result in personal injury or possible death.



POSSIBLE DAMAGE TO EQUIPMENT

Caution notes indicate any condition or practice which if not strictly observed or remedied, could result in damage or destruction of the equipment.

These safety instructions should be considered in a user's Safety Program. They are not intended to take away the responsibility of the user to formulate a comprehensive Safety Program and must not be considered as such. Rather, they are suggestions to cover the more important aspects of personnel safety related to Induction Motors. The user must establish a Safety Policy in accordance with the provisions of Governmental Regulations and Departmental Safety Rules for operating and maintaining safety of the equipment.

Hitachi, Ltd. neither condones nor assumes any responsibility for user practices that deviate from these instructions.

All personnel associated with installation, operation and maintenance of this equipment should be thoroughly instructed and supervised regarding Induction Motors in general and also, the particular model of equipment with which they are working. This manual should be closely studied and followed.

(b) GENERAL

An Induction Motor is designed to provide safe and reliable operation. It also includes some integral features that protect the equipment from damaging malfunctions. Personnel must become thoroughly familiar with these safety instructions and must observe them during all activities. Maximum safety of personnel must be of primary importance, closely followed by protection of equipment from damages. Careful observation of the requirements for safe equipment operation will minimize hazards to personnel.

Safety instructions include four categories: WARNINGS, CAUTIONS, FIRST AID, and DETAILED INSTRUCTIONS, which are covered in this section. In addition, many of the WARNINGS and / or CAUTIONS are given individually wherever applicable, with the various procedures throughout this manual.

First Aid procedures given here are not all-inclusive and represent only those procedures essential for preservation of life. Additional First Aid information such as those provided in a Red Cross First Aid Manual should be readily available, as well as standard First Aid kits containing basic First Aid equipment. A physician must always be summoned in the event of personal injury.

(c) PRELIMINARY SAFETY INSPECTION

A preliminary walk-around, visual safety inspection of the site must be performed before beginning any procedure. This inspection must include applicable items listed below as well as any others that may be specific or different for the installation. Any actual or potential hazard must be corrected before proceeding.

- Know the locations of emergency shut-off valves, switches, telephones, emergency shutdown provisions, etc.
- Become familiar with special emergency procedures that may be applicable to specific installation.
- Know the locations of fire extinguishers and other emergency and protective equipment and become familiar with their operations. (See Detailed Instruction 1.)
- Look out for safety hazards such as leaking gas, sour gas, condensate in drip pans, drain lines etc., high voltages, high pressures and other obvious hazards.
- Make sure that the equipment and its vicinity are clean and unobstructed; ensure inlet and outlet vent lines have no obstructions.
- Check if personnel are working on other equipment in the area and whether such work is of hazardous nature that precludes work on the Hitachi equipment.

(d) WARNINGS

The following warning notes cover Induction Motors. These warnings applicable to the particular equipment as well as others not listed, which may be applicable to the specific installation, must be scrupulously observed during all service procedures. Failure to observe these warnings could result in injury to personnel or death. The order of listing here does not indicate the order of their importance; each item is equally important to overall personnel safety.



- **Ensure other personnel are in close proximity. Never work alone.**
- **Never wire around automatic shutdown devices; this protection is incorporated to prevent injury to personnel and damage to equipment.**
- **When working on non-operating equipment, always lock out the start circuit by opening the control circuit breaker and moving the master control switch to OFF. Attach temporary “DO NOT START” tag to the control switch to warn against inadvertent closing of the switch.**
- **Check and ensure that operation of switches and valves will not endanger personnel and/or equipment.**
- **Do not allow any bare wires on or in the vicinity of the equipment.**
- **Do not step on live bare conductors, electrical conduits or junction boxes or use them as supports.**

- **Insert grounding rods in a suitable location to prevent tripping which may result in injury to personnel.**
- **Do not allow smoking, open flames or spark-producing devices in the vicinity of the equipment at any time.**
- **Protect your ears against high noise levels during operation.**
- **Wear safety helmets for head protection, safety goggles, ear protective device, safety-toe footwear, protective clothing, etc., wherever applicable.**
- **Avoid touching hot sections of the equipment.**
- **Eliminate any steam leaks or oil leaks as soon as they are detected.**
- **Ensure that the system pressure is zero before disconnecting any system line.**
- **Stand at a safe distance from all pressure lines and fittings during starting of the equipment.**
- **Wear suitable protective equipment (eye and face protection, goggles, gloves, etc.) and observe proper fire precautions when using cleaning solvents or solutions. Avoid skin contact with solvents or solutions and inhalation of fumes.**
- **When performing welding or cutting procedures on the equipment, observe requirements stipulated in the provisions of the Governmental Regulations and Departmental Safety Rules if any. (See Detailed Instruction 2.)**
- **Ground and discharge all high-voltage circuits by using a heavy insulated cable and short each phase to ground before working on or around the equipment; residual voltages which could be stored and maintained for several hours after shutdown can give lethal electric shocks.**
- **Take corrective action or report to your supervisor, any uncovered or unguarded holes or openings. These holes are to be securely covered or barricaded.**
- **Use lifting aids or get assistance to lift heavy or bulky loads. Adopt the practice of bending your knees and lifting with your leg muscles. The repetitive stooping or bending of your back, even without a load, will eventually lead to back trouble.**
- **X-rays and Gamma rays are used for examination of welds. Unless authorized to enter, stay away from an area when you see Warning signs such as: “UNDER NO CIRCUMSTANCES MUST UNAUTHORIZED PERSONNEL PASS BEYOND WARNING SIGNS.”**
- **Ground wire in accordance with OSHA.**
- **Ensure that any system, which is unsafe to operate, is locked out and the controls and switches are tagged with a “DO NOT OPERATE ” tag.**
- **Access ladders (See Detailed Instruction 3.)**

- Scaffolds and work platforms (See Detailed Instruction 4.)
- Cranes and hoists (See Detailed Instruction 5.)
- Electrical tools (See Detailed Instruction 6.)
- Hazardous substances and dangerous substances (See Detailed Instruction 7.)
- Accidental falls and drops (See Detailed Instruction 8.)

(e) CAUTIONS

The following caution notes cover Induction Motors. These cautions as well as others not listed, which may be applicable must be observed during all service procedures. Failure to observe these cautions could result in damage or destruction of the equipment. The order of listing here does not indicate the order of their importance; each item is equally important to overall equipment safety.

CAUTION

- **Do not allow Induction Motor to be rotated in a direction reverse to the specified rotation; reverse rotation can also cause serious damage to the driven machine.**
- **Cap all open lines and fittings during maintenance to prevent entry of contaminants into the system. DO NOT USE TAPE.**
- **Keep the equipment and vicinity clean and unobstructed. Keep maintenance working space clean to ensure clean assembly; cleanliness is important for Induction Motor.**
- **Do not overfill the oil sump of the oil lubricated sleeve bearings if provided for the equipment. Ensure that the oil level is maintained within the limits marked on the oil level gauge.**
- **Do not flex or twist cables unnecessarily; repeated flexing of wiring connections will lead to early fatigue failures.**
- **When disconnecting electrical cables, do not exert pulling force directly on the cables; exert pulling force by grasping the connectors only.**
- **Verify that check valves and other flow devices are installed for correct direction of flow.**

(f) FIRST AID

The following instructions for rendering First Aid in the event of any injury to personnel represent a brief outline of basic procedures for First Aid assistance in emergencies. The more comprehensive procedures, such as given in a Red Cross First Aid manual or equivalent, should be read and noted before the need for such actions occurs. In all cases, medical assistance must be obtained at the earliest.



Render First Aid with care to avoid further injuries and only to the extent required until arrival of proper medical assistance.

The steps given below are recommended in case of the mentioned mishaps:

• **Electrical Shock**

1. Turn off the electricity source. Do not touch the victim with bare hands until the circuit is de-energized.
2. Remove the victim from the accident site. Use dry insulating material e.g. dry leather, wood, rubber, etc. for protection while removing victim.
3. Remove false teeth, chewing gum, etc. from the victim's mouth and then perform cardio-pulmonary resuscitation if breathing has stopped and no pulse is detected.
4. Call for proper medical assistance.

• **Inhalation of Toxic Gases, N₂ , CO₂ , or Special Gases**

1. Remove the victim from the hazardous atmosphere.
2. Give artificial respiration.
3. Call for proper medical assistance.

• **Explosion**

1. Hemorrhages and wounds
 - a. Control bleeding by applying direct pressure at pressure points.
 - b. Use tourniquet only if other means are unsuccessful; use with care to avoid further injuries.
 - c. Treat for shock. Place the victim in reclining position and keep him warm.
 - d. Call for proper medical assistance.
2. Burns
 - a. Cover the burns lightly with sterile dressing.
 - b. Do not remove charred clothing.
 - c. Call for proper medical assistance.
3. Broken bones
 - a. Immobilize affected part by applying splint before moving the victim.
 - b. Call for proper medical assistance.

- **Burns from Sulphuric Acid or other acids**

1. Skin

- a. Immediately flush the affected parts with water for at least 15 minutes.
- b. Call for proper medical assistance.

2. Eyes

- a. Immediately flush with lot of water for at least 15 minutes.
- b. DO NOT attempt to neutralize the acid by applying any base substance.
- c. Call for proper medical assistance.

(g) DETAILED INSTRUCTIONS

i. DETAILED INSTRUCTION 1 - FIRE PROTECTION

- The basic elements necessary for the production of fire are flammable materials, oxygen (air), and an ignition source. Fire prevention involves keeping any one of these elements away from the other two.
- Adequate back-up fire fighting equipment must be available on site. Do not interfere with this vital equipment. Fire hydrants, hoses and extinguishers are exclusively for the fighting of fires. Ensure that any empty or faulty equipment is handed over to your supervisor.
- Familiarize personnel with all the fire fighting equipment in the area. Never use conductive extinguishers such as water or foam to extinguish electrical fires.
- Have a proper working communication system for reporting any fire detected.

TABLE 1: Types of Fire and Selection of Appropriate Portable Fire Extinguishers

Type of fire	Water	Foam	CO ₂	Dry Chemicals
A. Combustible solids e.g. wood, paper, clothing etc.	○	○	--	○
B. Flammable liquids e.g. oil, paint, petrol etc.	--	○	○	○
C. Fires involving Electrical Hazards	--	--	○	○

O: Applicable ; -- : Not Applicable

ii. DETAILED INSTRUCTION 2 - WELDING AND CUTTING

- Oxygen and Acetylene cylinders must be secured at all times and used in upright position. They should be transported using approved lifting boxes or cradles. They must never be lifted or lowered using a sling.
- Use proper facemasks to prevent eye injury from welding arc flash. Also, protect the body and other combustible material from welding sparks and hot metal.
- Provide adequate ventilation in areas where fumes are likely to get accumulated.
- Switch off electric welding equipment at the main switch when welding is finished. Earthing cable should be clamped as close to the weld point as possible, keeping in mind, electrical cabling, bearings and motors that can get damaged through stray currents.
- Welding and gas cutting operations should be performed by personnel who are qualified and competent in its use. Report any defective equipment to your supervisor - it may result in injury or fire if not corrected.
- All welding leads should be in good condition, with all insulation intact and no bare metal showing along its entire length.

iii. DETAILED INSTRUCTION 3 - ACCESS LADDERS

- Use ladders that are whole, undamaged and of approved construction.
- Ladders are to be secured during use. If it is essential to use a ladder before it can be secured, a second person should hold it steady at all times.
- Ladders should not be spliced or used as scaffold/work platform components. When used as access to elevated work areas, a ladder should extend one metre above the step-off point and be placed at an angle where the base of the ladder is a quarter of the ladder height away from the base of the scaffold or structure.
- Ladders with wire operated side rails or of metal construction should be used more than three meters away from any exposed electrical power source and should never be used in substations or for electrical installation works.
- Do not use timber ladders.

iv. DETAILED INSTRUCTION 4 - SCAFFOLDS AND WORK PLATFORMS

- All scaffolds, landings and work platforms should be provided with an access ladder that extends at least one metre beyond the step-off point; this provides you with a secure handhold when getting on or off the ladder. All access ladders must be secured so that the tie encompasses the stilt and one rung.
- All scaffolds/work platforms that are at or above 2.4 meters from a safe horizontal plane should be fitted with rigid guardrails of a height of one metre from the work platform. These guardrails should completely encompass the entire work platform.

- If person is required to work on an unguarded scaffold/work platform, he should use a safety belt that is secured to a suitable anchorage.
- Base plates and sound foundation material should be used for scaffold footings.
- The height of a mobile scaffold shall not exceed three times the minimum base dimension.
- All scaffold planks and kick boards shall be adequately secured.
- All scaffolds shall be erected by qualified and certified persons.

v. DETAILED INSTRUCTION 5 - CRANES AND HOISTS

- Only those persons authorized and licensed in accordance with local regulations or law shall operate or direct the operations of cranes and hoists.
- Never leave a load suspended without an authorized crane operator or supervisor at the controls.
- Do not enter within a radius of five meters below the suspended load.
- Riding on hoists, hooks or loads should strictly be prohibited.
- All outriggers are to be used when lifting and lowering loads. Do not attempt to lift a load without first determining its weight and the correct lifting equipments.
- All load hooks on cranes and hoists should be fitted with devices to prevent load displacement.
- All components used in a lifting tackle shall be of adequate capacity and shall be in sound condition.

vi. DETAILED INSTRUCTION 6 - ELECTRICAL TOOLS

- Faulty power tools are the most common cause of electrical accidents in construction work. Check them along with their fittings and leads before and during each use. Report any defective electrical equipment to the supervisor.
- Only qualified electricians are permitted to repair electrical tools, plugs, fittings and leads.
- Extension leads should be kept as short as possible and away from the floor or ground. They should be kept dry at all times.
- All electrical tools and leads must be inspected and suitably tagged by a qualified electrician at intervals of at least six months.
- Never lift or carry a power tool holding it by its leads. Ground wires which have come off and in contact with a live wire, will cause the metal casing to give electric shock.
- No portable power tool shall be used without a safety switch provided to trip the tool in the event of any leakage to ground. This switch may also be required as per the local regulations or laws. Each unit must be tested daily to check the functioning of the safety switch.

vii. DETAILED INSTRUCTION 7 - HAZARDOUS AND DANGEROUS SUBSTANCES

- Read the safety instructions on the containers of all such materials and ensure to take necessary precautions. If uncertain of the properties of any material, refer to the supervisor for instructions.
- Hazardous substances are to be stored and used carefully. All empty and disused containers and substances must be returned or correctly disposed off according to the project waste disposal procedures.
- All personal-protective equipment required to be used during the handling of hazardous substances must be used.
- Prior to the use of hazardous substances, ensure that correct medical and leak counter-measures are readily available.
- Observe all safety precautions and instructions related to hazardous substances.

viii. DETAILED INSTRUCTION 8 - ACCIDENTAL FALLS AND DROPS

- Avoid working at an elevated spot. Try to carry out as many operations on the ground as possible, by devising appropriate working procedures.
- When working at an elevated spot is unavoidable, it should be done on a work floor by setting up a scaffold or using a rolling tower.
- Use prescribed protective equipment. Do not act recklessly.
- Secure a work floor that is wide enough and convenient for working. Fasten it firmly to support it and to keep it from sliding down.
- When it is not possible to have handrails on a work floor, use such safety precautions e.g. wearing a safety belt, setting up a safety net etc.
- Do not place articles on a work floor. This will restrict the space and persons may stumble over them.
- Provide two persons if possible for operations that require the use of a ladder or portable ladders. One person should support the ladder or stepladders and keep a watch while the other person performs the required operations.
- Take into consideration, the weather conditions including rain and wind. Avoid performing operations at an elevated spot in bad weather conditions.

SECTION II

TECHNICAL INFORMATION

2.1 TECHNICAL DATA AND SPECIFICATION

MOTOR SPECIFICATIONS

- Standard : Test : JEC-2137-2000
Welding & Materials : JIS or Equivalent
Screw & Threads : ISO Metric
- Site Condition : Altitude : Below 3,281ft (1,000m)
Ambient Temperature : 40°C
- Type of motor : Three phase , squirrel cage
Forced-ventilated , asynchronous motor
- Type form (Protection) : Horizontal type : EFFZOA-KK (IP23W)
- Methods of cooling : IC17
- Pole : 6
- Starting method : V.F.D.
- Rating :

Ratings		Continuous
Output	(HP)	400
Voltage	(V)	600
Current	(A)	390
Speed	(min ⁻¹)	1170
Frequency	(Hz)	39
Efficiency	(%)	94
Power Factor	(%)	82
Slip	(%)	1.2

- Insulation class : Class F
Temperature rise limits
Parts Method of measurement Limits
Stator winding Resistance 105K
- Minimum service speed : 117min⁻¹
- Over speed : 1404min⁻¹
- Bearing type : Load side : Ball bearing , Type number : 6220C3
Opp. Load side : Roller bearing , Type number : NU220EMCM
- Accessories : Space heater 240V 1phase
- Weight (without blower set) : Approx. 3,307LB (1,500kg) (Net)

Note:

The data may be changed without notice. Please confirm the data with Hitachi for certification.

CAUTION

- Application: Non-hazardous area only
- This machine is of open-splash-proof construction. It is force-ventilated by a fan and requires an ample of cooling air. The cooling air should not contain combustible gases. If it is applied in an environment that may contain combustible gases, an adequate supply of non-contaminated cooling air must be provided.

2.2 CONSTRUCTION OF MOTOR

2.2.1 GENERAL CONSTRUCTION

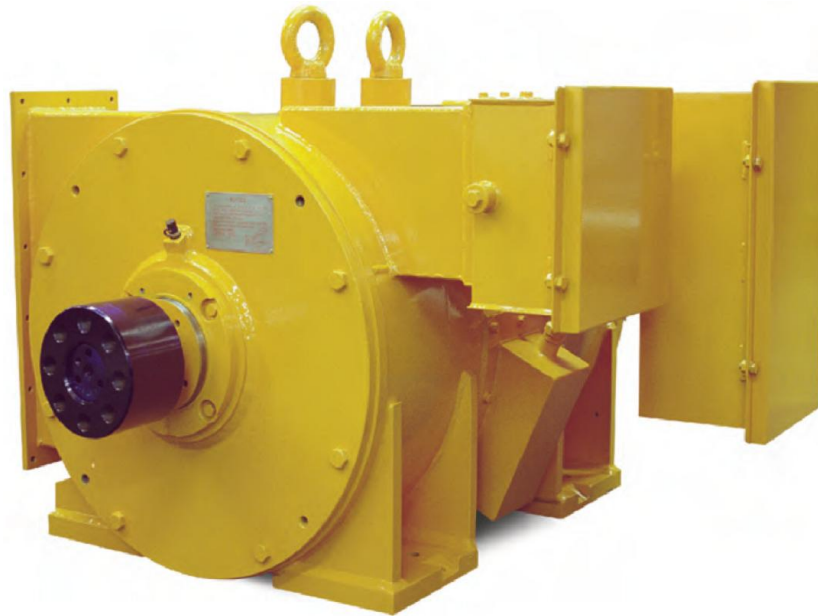

400HP 4P 600V 39Hz Three Phase Induction Motor

(1) Stator

The stator coils adopt the Class insulation using a Class F insulation material. After stator coils have been assembled to the stator core, they are vacuum-impregnated with varnish together. The stator core slots are designed as backward slots. And a ventilation space is provided at the slot opening to enhance the cooling effect. Stator coils are supported by steel rings to be resistible against vibrations.

(2) Rotor

The rotor is designed as a cage type. The rotor bar is made of copper, while the end ring is made of oxygen-free copper and joined by silver soldering. A clearance between the rotor bar and the rotor core is impregnated varnish to enhance the cooling effect. The shaft is made of special steel.

(3) Bearings

Type 6220C3 ball bearing is mounted on the drive end side, while Type NU220EMCM roller bearing is mounted on the opposite side. The roller bearing is a roller guide system bearing to be applicable to high-speed rotation. It is lubricated with “Shell ALVANIA RL2”.

TABLE 2.1 : List of Figures

Number	Title
FIGURE 2.1	Outline of 400HP Three phase induction Motor
FIGURE 2.2	Outline of Primary Terminal Box
FIGURE 2.3	Outline of Stator RTDs & Space Heater Terminal Box

2.2.2 ROTOR

HARD-WORKING , LONG – LASTING ROTORS

Hitachi squirrel-cage rotor comprises heavy copper bars and endrings. The bar and end-ring joints are designed to minimize stresses and stress concentrations during starting and running. The materials of bars and end-rings are copper or copper alloy which have high mechanical and thermal strength against severe motor applications.



2.2.3 BEARINGS

The bearing systems used in Hitachi Motors have been designed and engineered for continuous, reliable operation and easy maintenance. The both bearings are provided with bearing insulation.

Anti-friction bearings

Single-row cylindrical roller bearings are employed. The bearings are of heavy duty type to endure severe applications. The motor is provided with ball bearing on Drive end and roller bearing on Non-driven end. Combinations are chosen according to the motor output, speed and type of load. The bearing units allow regreasing to be performed while the motor is running. Used or excess grease is automatically drained off to maintain the appropriate amount of lubricant.

TESTING AND QUALITY ASSURANCE, WARRANTY AND SERVICE

TESTING

Our works are fully equipped for testing of motors as per JEC-2137. The following performance tests can be provided :

• **FULL PERFORMANCE TEST**

Test Item

- (1) Visual inspection of construction
- (2) Measurement of winding resistances
- (3) No load test
- (4) Locked rotor test
- (5) Temperature test (*)
- (6) Measurement of vibrations
- (7) Measurement of noise
- (8) Measurement of insulation resistance
- (9) Dielectric tests
- (10) Performance determination
- (11) Over-speed test

• **ROUTINE TEST**

Test Item

- (1) Visual inspection of construction
- (2) Measurement of winding resistances
- (3) No load test
- (4) Measurement of insulation resistance
- (5) Dielectric tests

** Temperature tests are carried out by means of Primary Superposed Equivalent Loading Method.*

QUALITY ASSURANCE, WARRANTY & SERVICE

Quality Management System : Hitachi has established a quality management system that complies with the requirements of ISO 9001:2008.

The Quality Management System has been certified and approved by Lloyd’s Register Quality Assurance Limited.



For Hitachi Works, Hitachi Ltd.		
Steam Turbines	Rolling Mills	Uninterruptible Power Supply Units
Gas Turbines	Water Turbines	Nuclear Fusion Equipment
Heat Exchangers	Electric Motors	Accelerators
Generators	Electric Converters	Superconducting Equipment

PRODUCT WARRANTY

The motors supplied are in conformance with the Hitachi Quality Requirements and are warranted by Hitachi, Ltd. The standard motor warranty is 12 months after commissioning or 18 months after delivery, whichever is earlier. Longer warranty periods are available on request.

SERVICE ORGANIZATIONS

Hitachi offers service assistance by

- Supplying necessary technical information for repair.
- Cooperation with the nearest local repair shop to customer.
- Dispatching Hitachi engineer(s) at Customer’s expense if it is necessary.

Hitachi is associated with service facilities throughout the world. A separate brochure is available with a list of recommended repair shops.

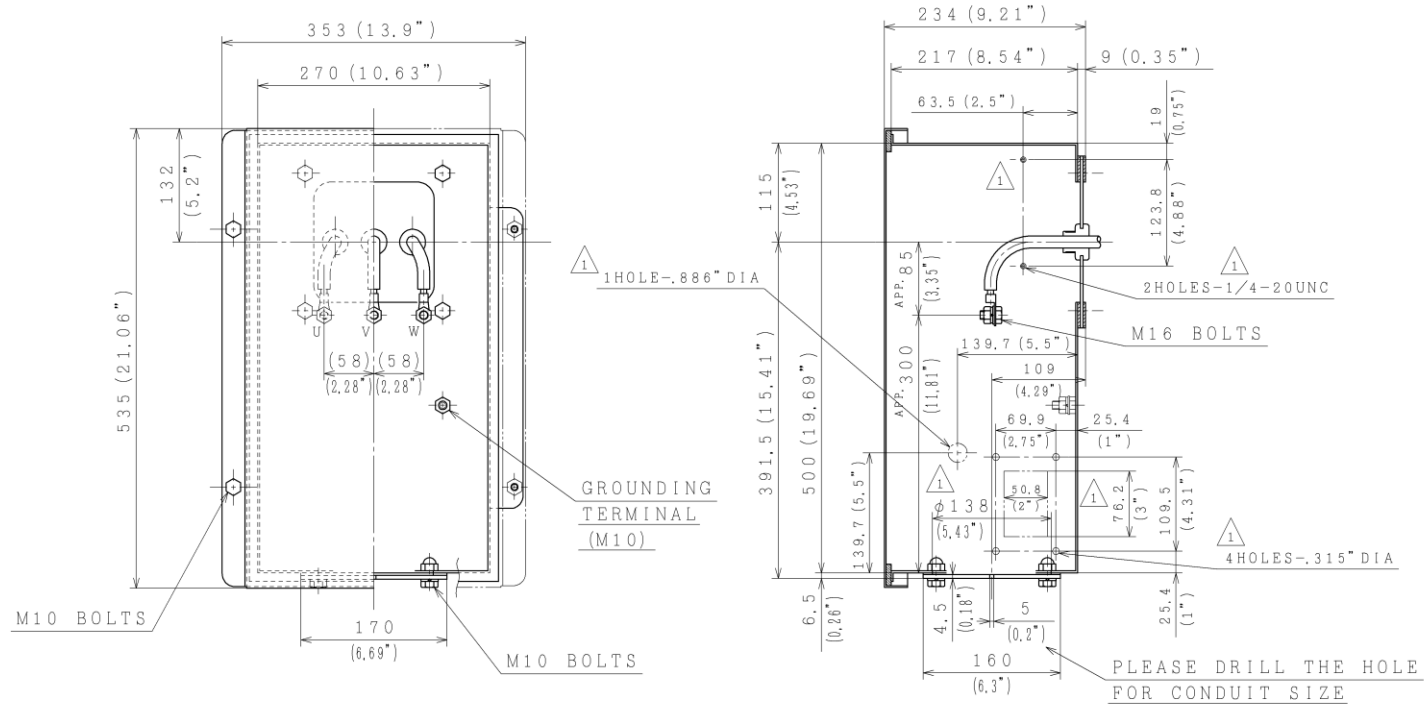

FIGURE 2.2 : Outline of Primary Terminal Box
II - 6

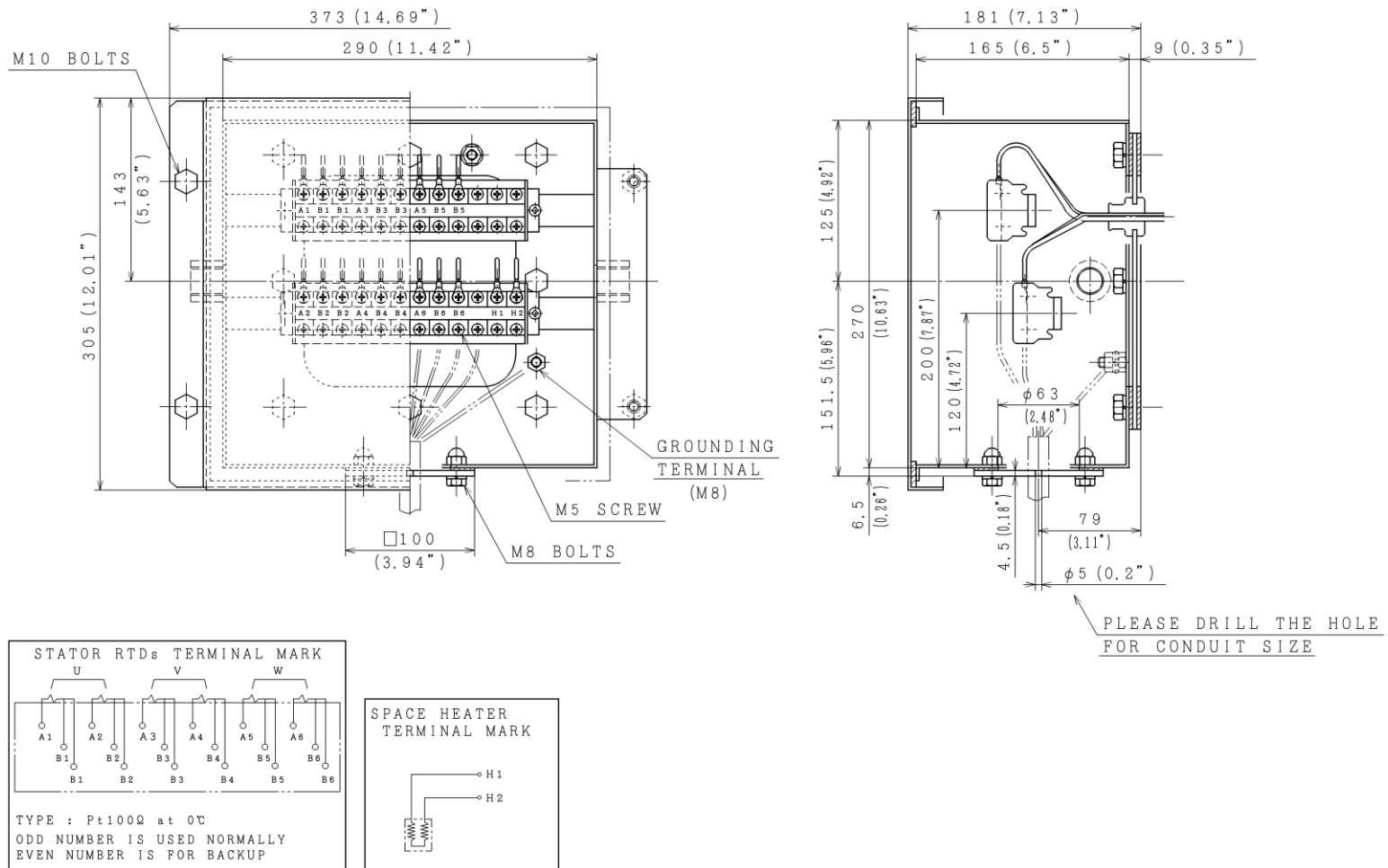

FIGURE 2.3 : Outline of Stator RTDs & Space Heater Terminal Box
II - 7

SECTION III

RECEIVING, HANDLING & STORAGE

3.1 RECEIVING

- Each package should be carefully inspected on receipt. Damages if any, should be reported promptly to the carrier and to the nearest representative of Hitachi, Ltd.
- Check the items contained in the packing case against the details given in the Packing List, particularly the small items which are likely to be overlooked, e.g. mounting bolts, etc.

3.2 HANDLING



- **Lifting by improper lifting lug(s) can cause severe injuries, death and / or damage to the electric motor.**
- **Lift by proper lifting lug(s) provided on the motor as indicated in the warning labels provided on the motor.**

When lifting the package by a crane, the wire ropes must be placed so that the center of gravity of the packing case is between the wire ropes. Special care must be taken not to damage parts such as the shaft journal, windings, ventilation box unit etc.

Refer to the weights indicated on the outline drawing of the motor for selection of appropriate lifting devices/equipments. Where there are no lifting facilities available, it is recommended to use strong wooden rollers or a tripod which is suitable to support the weight of the motor.

The motor should be lifted by using all the lifting lugs or lifting eyes provided on the stator frame, as indicated in the warning plates/labels fitted on the motor.

3.3 UNPACKING



- **Hazardous material can cause severe injuries, death or fire.**
- **The area should be well ventilated when using any cleaning fluid.**

Before unpacking, if the motor has been stored in an area with temperature lower than the ambient temperature, allow sufficient time for the temperature of the package to reach surrounding conditions to avoid condensation.

Anti-corrosion paint applied on the shaft extension and machined surfaces can be easily removed with kerosene or a solvent, using hair bristle paint brushes.

Shaft-locking bolts and clamps if provided to prevent shaft movement during transportation, shall be removed.

3.4 **STORAGE**

After unpacking, if the motor is not to be commissioned immediately (up to three months), store the motor in a clean and dry place with proper ventilation, under a proper cover. Keep the motor clear of water by placing it on suitable blocks. Avoid places where the temperature is likely to drop suddenly and cause moisture to condense on the finished surfaces. At all times, should such condensation occur, it must be removed immediately with dry cloth ; otherwise corrosion will result. The windings should be protected from termites and rodents.

During storage, the windings should be protected against moisture condensation. Measure Insulation Resistance at frequent and periodic intervals and keep records. Avoid freezing by some safe and reliable heating system which will always keep the temperature of the machine above dew point temperature of the surrounding air. If the motor is provided with space heaters, the heaters should be energized. Similarly, in the case of grease lubricated bearings, fill in the required quantity of the recommended grease. Once in a fortnight, manually rotate the rotor through several revolutions.

The finished surfaces of the machine are coated with anti-corrosion paint or grease. If the anti-corrosion paint has come off, the surface must be cleaned, dried and anti-corrosion paint applied again.

SECTION IV

INSTALLATION

4.1 PREPERATION OF INSTALLATION OF THE MOTOR

4.1.1 METHOD OF FOUNDATION AND TYPES OF FOUNDATION BOLTS

(a) Method of Foundation

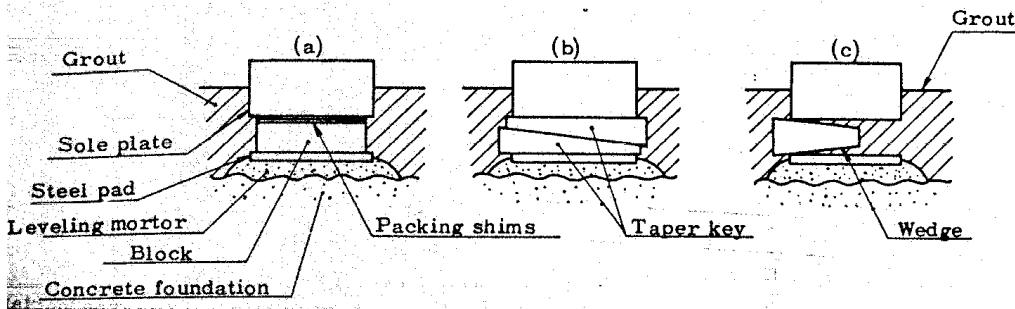

(b) Types of Foundation Bolts

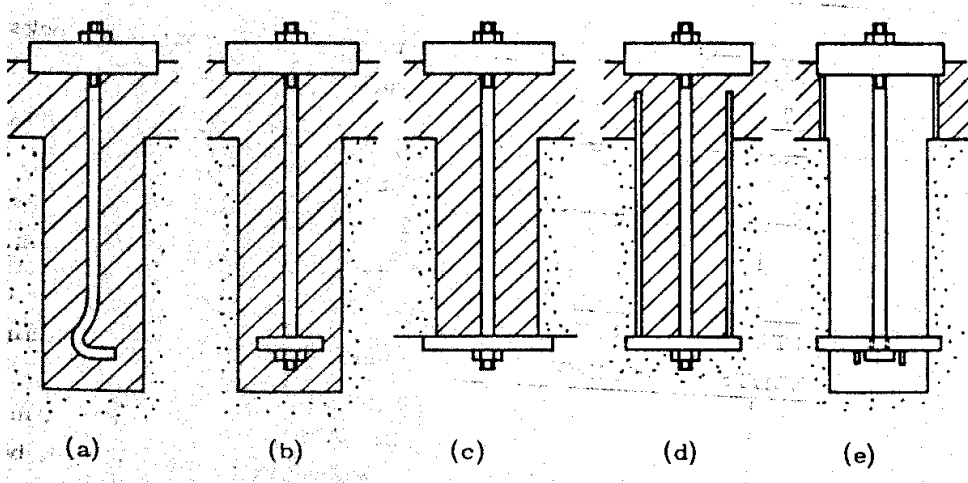

4.1.2 INSTALLATION

Motor should be installed in a non-hazardous area where they will be protected from moisture, escaping steam, drips from pipes and any acids, alkalis, oils, or gas, as well as from dust, dirt, lint, or other injurious substances. If motors are to be installed in a hazardous area, make sure that the motor is suitable for installation in that hazardous area.

When connecting the motor to the driven machinery, be sure that the foundation is properly set before attempting to align or grout the motor. Particular care must be taken in the alignment of machines for direct or gear drives.

The bearings are mounted on bearing unit supports (bearing brackets) which are dowelled and bolted to the stator frame. All air gap and end play adjustments are made at the factory. The

motor should be mounted on a rigid and solid foundation. Level the base in accordance with paragraph No. 4.1.3 - MOUNTING PROCEDURE OF MOTOR BASE.

When a motor and a driven machine together have four or more bearings, flexible couplings may be used to facilitate alignment. Three-bearing arrangement generally requires a rigid coupling. Electrical connections are covered in paragraph No. 4.4 - CONNECTION TO POWER CABLE.

Before starting the motor for the first time, see paragraph 5.1 INSPECTION DURING INITIAL COMMISSIONING.

4.1.3 MOUNTING PROCEDURE OF MOTOR BASE

Motor sole plates or motor base must be mounted on the foundation by the following procedure and record of alignments must be kept.

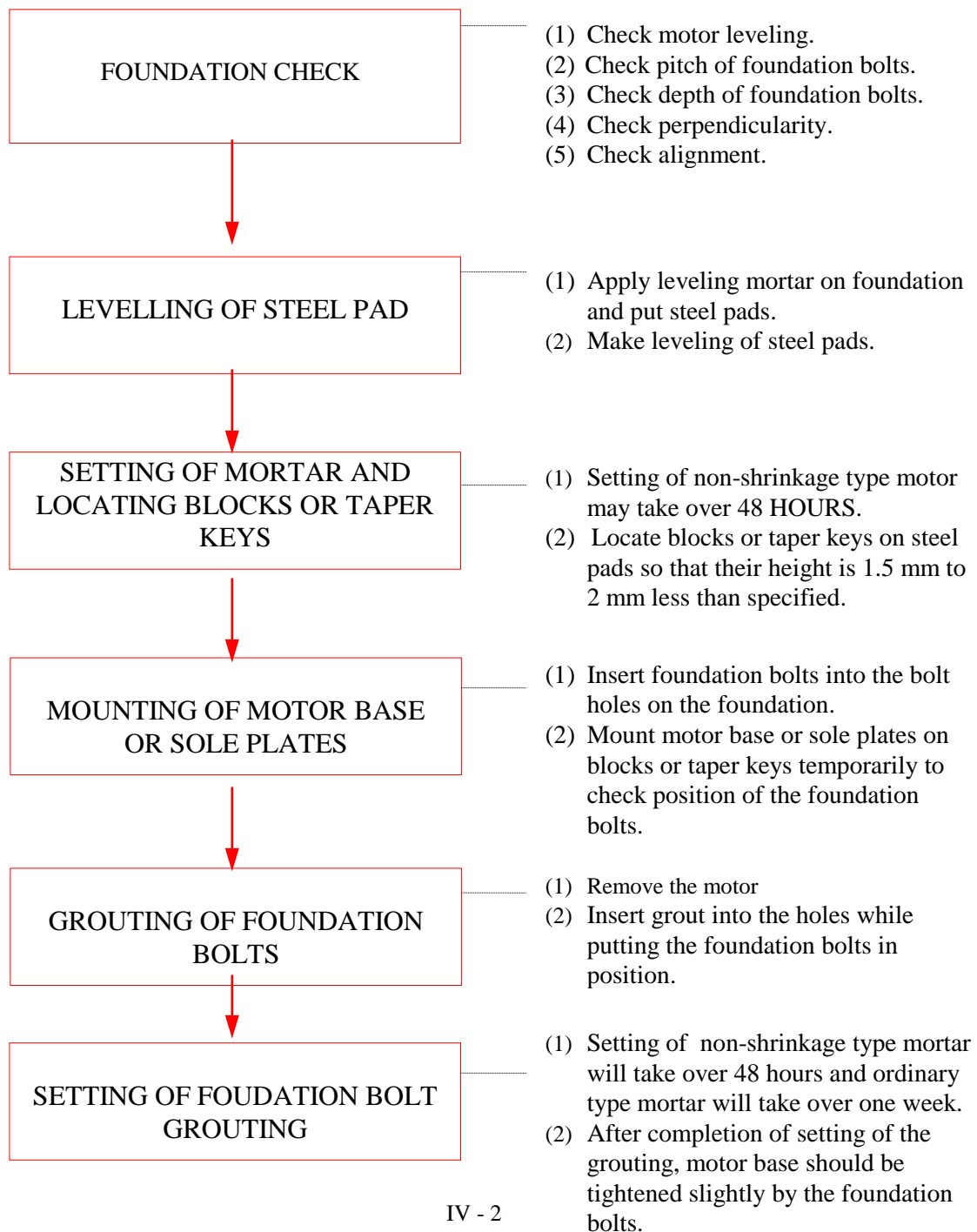

MOUNTING PROCEDURE OF MOTOR BASE (Contd.)

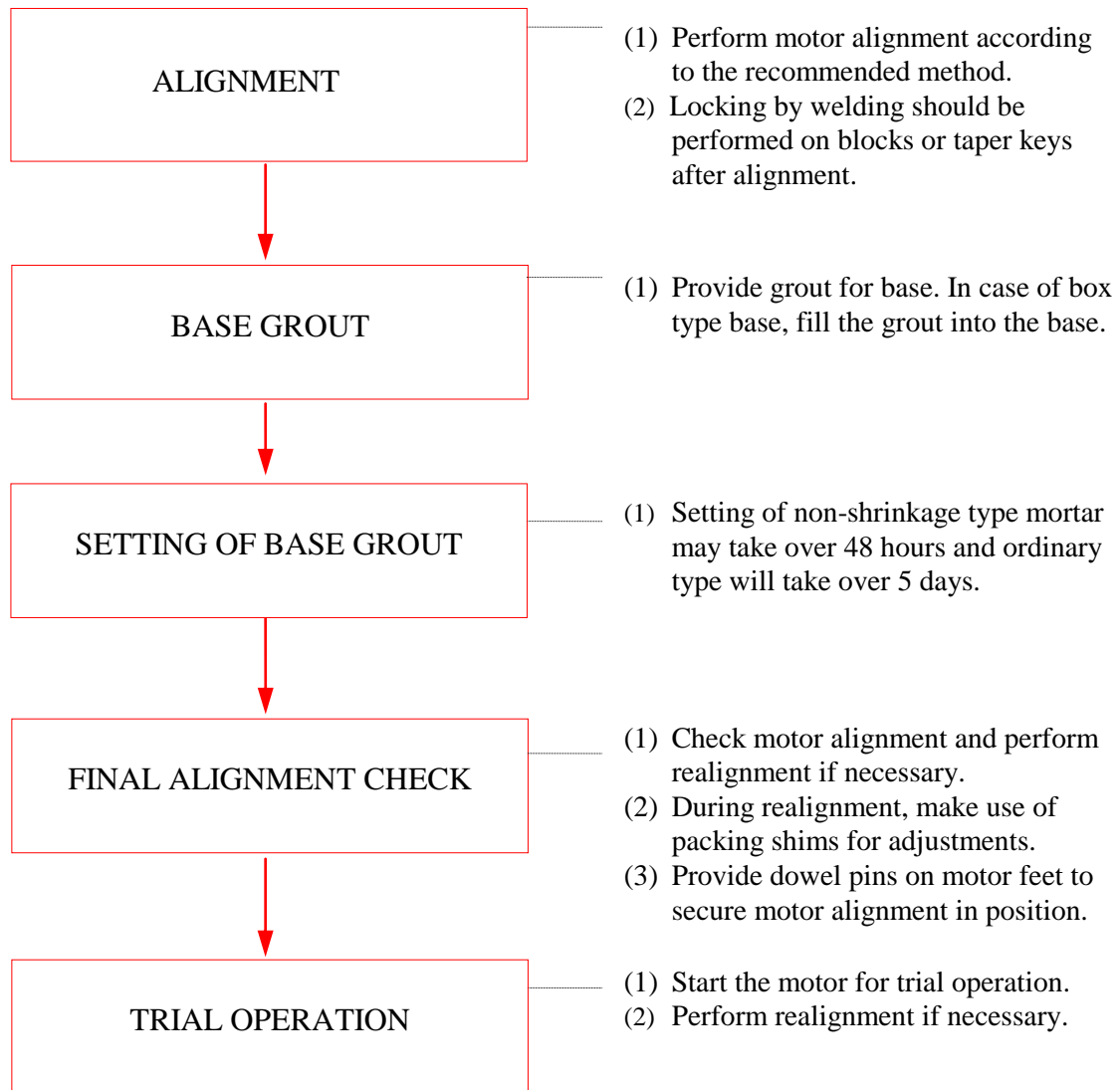

4.1.4 TOLERANCES FOR MOTOR INSTALLATION

The Horizontality of the base and the motor should be less than : 0.05 mm/m ($0.6 \times 10^{-3} \text{ inch/ft}$).

4.2 COUPLING

4.2.1 ALIGNMENT

Couplings should be shrink fitted. Do not heat flexible couplings which have rubber, leather or other non-metallic parts which are not easily removable.

While erecting the machines, care should be taken to see that both coupling faces are true and at right angles to the centerline of their respective shafts before aligning the machines. It is also

advisable to check the outside of both halves of the coupling to see that they are concentric with the center.

Flexible couplings are not primarily intended to take care of any error in alignment; they should be aligned originally with as much care as with solid couplings. If good initial alignment is obtained, the couplings will have greater capacity to take care of subsequent operating misalignment and the life and satisfactory operation of the flexible couplings will be greatly enhanced. Connecting links, pins, or buffers between the two halves of flexible couplings should be removed while the machines are being aligned. On some types of flexible couplings, periodic lubrication is necessary; the coupling manufacturer's instructions should be followed.

For high speed motor, greater care is necessary in aligning. Occasionally, after operation, the alignment should be rechecked and then corrected if necessary.

4.2.2 TOLERANCE FOR MOTOR ALIGNMENT

Tolerances of motor alignment must be in accordance with TABLE 4.1.

TABLE 4.1 : Tolerances for Motor Alignment

Speed (min-1)	Eccentricity between half couplings	Parallelism between faces of half couplings
Less than 3000	within 0.03 mm (1.18 x 10 ⁻³ inch)	within 0.03 mm (1.18 x 10 ⁻³ inch)

The above tolerances should be checked periodically - more than once per month.

4.3 TIGHTENING TORQUES OF BOLTS AND NUTS

Tightening torques of bolts and nuts shall be as indicated in the following tables.

TABLE 4.2: Standard Tightening Torques (Standard Threading)

Bolt Size	Tightening Torque	
	(Kg-cm)	(Ft-lb)
W3/8 (M10)	200	14
W1/2 (M12)	460	33
W5/8 (M16)	960	69
W3/4 (M20)	1,750	126
W7/8 (M22)	2,750	198
W1 (M24)	4,120	297
W1 ¼ (M30)	8,230	595

TABLE 4.3: Standard Tightening Torques (Tapered Threading)

Bolt Size	Tightening Torque	
	(Kg-cm)	(Ft-lb)
3/8 - 16 UNC	215	15
1/2 - 13 UNC	510	36
5/8 - 11 UNC	1,000	72
3/4 - 10 UNC	1,780	128
7/8 - 9 UNC	2,850	206
1 - 8 UNC	4,260	308
1 1/4 - 7 UNC	8,800	636
1 1/2 - 6 UNC	14,700	1060
1 3/4 - 5 UNC	23,600	1700

Note:

- Tolerance of tightening force : ± 20 percent.
- Bolt size given in parenthesis indicates the equivalent ISO standard bolts.

4.4 CONNECTION TO POWER CABLE

CAUTION

- **Direct starting method is not considered. Be sure to start by using inverter.**

Before connecting to the power system, check the motor windings for Insulation Resistance in accordance with paragraph 5.1.1 and dry them out if necessary.

The direction of rotation of the motor should be checked before coupling to the driven equipment, particularly if the equipment can get damaged by incorrect rotation. Before operating the motor for the first time, refer paragraph 5.1.4 INSPECTION BEFORE STARTING.

4.5 RECOMMENDATION OF LUBRICANT

4.5.1 CONTINUOUS OPERATION

The continuous operation of Electric Motors is vitally dependent upon proper lubrication of their bearings.

Specific instructions relating to the bearings, housings, piping, oil level, etc., are specified in this Instruction Manual. The motor is provided with a caution plate indicating type of lubricant, renewal interval and quantity of lubricant. It is the responsibility of the operator to determine that these instructions have been complied with before starting the motor for the first time.

The lubricating oil to be used is the responsibility of the purchaser of the equipment and should be a high grade mineral oil as recommended for electric motor use by a reputed oil manufacturer and also specified on the motor outline drawing.

4.5.2 GREASE

Recommended grease and the names of manufacturers are shown in TABLE 4.4.

TABLE 4.4 : Recommended Grease

Item	Name of grease	Name of manufacturer	Soap type (Base)	Dropping point	Cone penetration at 25 °C JIS-K-2225 or equivalent standard	Usable temperature range
1	COSMO WR2	COSMO OIL	Special Na	Above 230 °C	275	-40 °C to 140 °C
2	SHELL Alvania RL2	SHELL OIL	Li	181 °C	275	-25 °C to 110 °C
3	SHELL Alvania S3	SHELL OIL	Li	182 °C	242	-10 °C to 110 °C
4	BEACON 2	MOBIL OIL	Li	187 °C	270	-30 °C to 100 °C
5	MULTINOC 2	ENEOS	Li	212 °C	278	-20 °C to 120 °C
6	MULTEMP LRL3	KYODO YUSHI	Urea	205 °C	220-250	-35 °C to 130 °C

Note:

- (1) Li = Lithium
- (2) Na = Sodium

The motor is fitted with a caution plate indicating type of grease, greasing interval and quantity. Selection of grease, greasing interval and quantity must be made in accordance with the caution label.

SECTION V

OPERATION



- **Hazardous voltages can cause severe injuries, death or damages to the motor. Turn off power, rack out starter / breaker and lock the same before accessing the motor.**
- **Improper operation can cause personal injuries or damages to the motor. Operate within nameplate ratings and in accordance with instructions given in this manual.**

This section describes information on operation of three phase Induction Motor.

5.1 INSPECTION DURING INITIAL COMMISSIONING

5.1.1 INSPECTION BEFORE TRIAL START

- Inspection before trial (first) starting must be made according to the procedures - (1) to (10) mentioned below.
 - For the second and further starting, procedure (8) to (10) are to be followed.
- (1) Check if all connections and cable type and size are as specified.
 - (2) Check if all connections are tight and necessary insulation, if any, like taping or bracing has been done correctly.
 - (3) Check that motor frame and all terminal boxes are properly grounded.
 - (4) Confirm that settings of all overload relays are correct. Setting with 100 percent to 105 percent is preferable, but do not exceed 105 percent of normal rated current of the motor. Time delay setting for starting should also be adjusted for starting duty and locked rotor condition.
 - (5) Check alignment of the motor.
 - (6) Confirm correct operation of starting and control equipment.
 - (7) Using suitable megger, measure Insulation Resistance and confirm that the value exceeds that obtained from the following equation :

$$\text{Insulation resistance} = \frac{\text{Rated Voltage (V)}}{\text{Rated Output (kW)} + 1,000} \quad (\text{M}\Omega)$$

- (8) Confirm condition of the driven machine and that all controls are in the start position.
- (9) Confirm that all ventilation openings and ductings if any, are clear and that all bolts and nuts are tightened.
- (10) Check oil levels for oil lubricated bearings and the oil flow rate in case of forced oil lubricated bearing.

5.1.2 LOAD CONDITIONS FOR TRIAL START

Start the motor in uncoupled condition to make sure that the motor is in sound condition. Stop the motor and couple it to the load and restart the motor. The load should be reduced to the lowest limit as possible and then increased gradually to normal rated condition.

5.1.3 INSPECTION DURING MOTOR RUNNING



- **Rotating parts can cause severe injuries or death. Do not touch couplings and motor cooling fans when the motor is running.**
- (a) Check direction of rotation of the motor.
- (b) Confirm that the motor runs quietly without any abnormal noise.
- (c) Confirm that the motor runs smoothly without abnormal vibrations.

5.1.4 DIRECTION OF ROTATION



- **Hazardous voltages can cause severe injuries, death or damage to the motor.**
- **Turn off power and rack out the starter before accessing the motor.**
- **Take residual voltage measurement before accessing terminal box and discharge the terminals.**

An arrow indicating the direction of rotation is generally fitted on the stator frame. Confirm that the direction of rotation of the motor matches the direction of the arrow. If incorrect, stop the motor immediately and check connections of power supply.

5.1.5 LIMITS OF STARTING FREQUENCY

Unless otherwise specified, the motor is capable of :

- (a) Two consecutive starts from cold condition.
- or
- (b) One start from hot condition
- and

One or two starts in a day is recommended.

The motor should not be subjected to more starts than specified.

Note:

- * Cold condition : motor is at ambient temperature.
- * Hot condition : motor has been running on load for more than approx. 2 hours.

5.2 OPERATION

5.2.1 LIMITS OF VARIATION IN VOLTAGE, CURRENT AND FREQUENCY

Variations in the power supply shall not exceed:

- (a) Voltage : Less than rated value (AC 600V)
- (b) Frequency : Continuous : 1170min^{-1}
- (c) Combined : Voltage – Frequency ratio is less than 600V/39Hz
Voltage &
Frequency

The current value at rated load, voltage and frequency is inscribed on the name plate.

All the performance figures like efficiency, power factor, temperature rise etc are at the rated voltage and frequency and, are not applicable when the voltage and frequency vary within above limits.

The motor should not be operated when the supply variations exceed the above limits.

5.2.2 VIBRATION AND NOISE

Generally, any motor will have vibration and / or noise under operating conditions. The motor operator must pay as much attention to vibrations and noise as is given to voltage, current and frequency because these are the most apparent signs of abnormal behavior of a motor.

5.2.2.1 VIBRATION

The vibrations of a motor is classified as follows:

- (a) Forced vibrations unbalanced coupling, vibration in foundation or reciprocal force etc.
- (b) Free vibration by shock ..shock jotting etc.
- (c) Self exciting vibrationfriction, surging etc.

If abnormal vibrations occur, detect the cause. Some of the common probable causes of vibrations are listed as follows:

- (1) Vibrations in No load and uncoupled condition.
 - (a) Unbalance in rotor.
 - (b) Uneven air gap length.
 - (c) Single phase operation.
 - (d) Shorting between coils or phases.
 - (e) Bad bearing or bearing condition.
 - (f) Unbalance in coupling.
 - (g) Abnormal rubbing with rotating parts.
 - (h) Bending of shaft.
 - (i) Improper foundation and installation.
 - (j) Looseness of rotor- mounted parts.
- (2) Vibrations in No load and coupled condition.
 - (a) Residual unbalance in the total rotating system.
 - (b) Looseness of foundation bolts or mounting bolts of stator frame.
 - (c) Gaps between base and foundation or gaps between base and stator frame.
 - (d) Resonance with foundation.
 - (e) Improper alignment.
 - (f) Uneven shrinkage / setting of foundation concrete.
 - (g) Critical speed of total rotating system.
 - (h) Improper method of fitment of couplings.
 - (i) Bending of shaft.
 - (j) Vibration transmitted from driven machine.
- (3) Vibrations in coupled condition and vibration changing with load conditions.
 - (a) Looseness of rotor sub-assemblies or parts fitted on the rotor.
 - (b) Uneven air gap.
 - (c) Mismatch between magnetic centers of stator and rotor.
 - (d) Cracks of rotor bar and/or end ring (in case of cage type rotor).

- (4) Other causes
 - (a) Improper fitment of coupling on shaft.
 - (b) Improper fitment of bearings on bearing unit supports (bearing brackets).
 - (c) Improper fitment of bearing unit supports on to stator frame.

5.2.2.2 NOISE

Noise is classified roughly into windage noise and magnetic noise.

The windage noise is induced by rotation of the rotor and the cooling fans without any relation to load conditions.

The magnetic noise varies with load condition and disappears when power supply is switched off.

5.2.3 RECOMMENDED SETTING VALUES

CAUTION

- **Restart of motor after stoppage due to power failure may cause damages to motor and/or driven machine. Turn off starter and associated equipment and set them for start position.**

Following are Trip setting values for detectors in the motor, if fitted.

TABLE 5.1 : Thermal Setting Value

Type	Setting value
Stator winding RTDs	A setting value : 266F (130°C)

Above setting values are based on surrounding temperature at 40°C.

SECTION VI

MAINTENANCE

This chapter describes maintenance information for Three Phase Induction Motors.



- **Hazardous voltages can cause severe injuries, death or damage to the motor. Turn off power, lock out and rack out starter before accessing the motor and control circuits.**
- **Hot temperatures may cause injuries to personnel. Do not touch space heater(s) if provided.**

6.1 PERIODIC INSPECTION

6.1.1 INSPECTION POINTS



- **Hazardous voltages can cause severe injuries, death or damage to the motor. Take residual voltage measurement before accessing the parts and discharge the parts.**

Generally, three types of inspections shall be carried out :

- (1) Routine Inspectionto inspect for detection of abnormal matter.
- (2) Monthly Inspection.....to inspect, clean and repair without disassembly of motor.
- (3) Yearly Inspectionto inspect, clean and repair with disassembly of motor.

Following are typical inspection points.

Inspection parts	Routine Inspection	Monthly Inspection	Yearly Inspection
Stator	(1) Measurement of voltage, current, vibration, temperature of stator frame, temperature of outlet air, ambient temperature and humidity. (2) Number of starts.	Measurement of Insulation Resistance.	(1) Removal of dust. (2) Check for looseness of stator core & of slot wedges. Measurement of (3) Insulation Resistance before and after disassembly. Inspection of coil (4) surfaces. (5) Measurement of air gap.
Rotor			(1) Check for looseness of core, damage to teeth etc. (2) Removal of dust. (3) Looseness of bolts.
(Cage type Rotor)			Deformation of rotor bars and end rings.
Bearings	(1) Noise. (2) Vibration. (3) Temperature.	Re-tightening of bolts and nuts.	Damages on the bearings.

Typical inspection points(Continued).

Inspection parts	Routine Inspection	Monthly Inspection	Yearly Inspection
(Roller type)		Greasing.	Cleaning and inspection.
Space Heater			Measurement of Insulation Resistance before and after disassembly.

Note:

- In the Monthly Inspection checks, parts that cannot be checked in detail during Routine Inspection should be checked and suitable measures taken.
- Yearly Inspection should be carried out in detail.

6.1.2 INSULATION RESISTANCE



- Hazardous voltages can cause severe injuries, death or damages to the motor. Do not touch uninsulated electric terminals.

Stator

When a motor is idle for a long period, the insulation of the winding may absorb moisture and the winding Insulation Resistance will drop. Before starting the motor, check that the Insulation Resistance value exceeds that obtained from the formula given below, using a suitable megger. If the resistance is less than the calculated value, the motor winding must be dried out.

$$\text{Insulation Resistance} = \frac{\text{Rated Voltage (V)}}{\text{Rated output (kW)} + 1,000} \text{ M}\Omega$$

Space Heater

Immediately after load testing, measure the insulation resistance between the charge port and non-charge port. Resistance value exceeds that obtained from the formula given below, using 500V megger.

$$\text{Insulation Resistance} \geq 10 \text{ M}\Omega$$

6.1.3 HIGH POTENTIAL TEST

High Potential tests are carried out on all motors at the manufacture's plant. Therefore, when it has to be carried out at site, the test voltage shall be as given below:

$$\text{Test Voltage} \leq 1.5 \times E \quad (E : \text{Rated voltage } 600\text{V})$$

Duration of the test shall be 1 minute. Measurement of the Insulation Resistance using a suitable megger must be carried out before the high potential test.

Charging current may flow right after commencement of High Potential test: This charging current should not be confused with break down current.

Sudden increase in primary current together with drop of secondary voltage indicates that the insulation has broken down. This can be confirmed by using the megger. Insulation Resistance will be very low or zero.

6.2 TROUBLESHOOTING

In the event of occurrence of any trouble, stop the motor immediately. Refer the tables given below for guidelines for a preliminary analysis of the trouble and countermeasures and take appropriate actions.

TABLE 6.1 : Typical Troubles associated with Motors, Causes and Countermeasures.

TABLE 6.2: Typical Troubles associated with Anti-Friction Bearings, Causes and Countermeasures.

TABLE 6.1 : Typical Troubles Associated with Motors, Causes and Countermeasures.

Trouble.	Likely Causes	Countermeasure / Further Checks
Motor does not start	(1) Low voltage.	(a) Check voltage and correct if found low. (b) Increase the voltage tapping
	(2) Large voltage drop.	(a) Check voltage variation at output terminal of starter, before and during starting. (b) Repeat the same at the motor terminals.
	(3) Open circuit or unbalanced voltages.	Repair where the circuit is open.
	(4) Faulty connections.	Repair the faulty connections.
	(5) Faulty contacts.	Repair the faulty contacts.
	(6) Broken cables or unbalanced starting resistances.	Measure the resistances and correct.
	(7) Open stator or rotor windings.	Measure the resistances or currents and correct.
	(8) Wrong stator windings connections.	Rectify connections.
	(9) Faulty rotor - cracked or broken bars (cage rotor type).	Replace with new rotor bars or repair complete rotor.
	(10) Rubbing between stator core and rotor core.	(a) Check by rotating by hand. (b) Check by disassembly.
	(11) Faulty bearings.	(a) Check by rotating by hand. (b) Check by disassembly.
	(12) Starting torque low.	(a) Check voltage at motor terminal during starting.
	(13) Overload	Reduce the loading on the motor.

TABLE 6.1 : Typical Troubles Associated with Motors, Causes and Countermeasures. (Continued)

Trouble.	Likely Causes	Countermeasure / Further Checks
Long Acceleration Time.	(1) Low voltage. (2) Faulty rotor. (3) Overload or low starting torque.	Check voltage drops. (a) Check brazed joints between bars and short circuiting rings. (b) Check unbalance in rotor windings. Check loading condition and terminal voltages during starting.
Abnormal Noise.	(1) Resonance due to loosened components. (2) Single phase operation or voltage unbalance.	Find exact cause of unbalanced air gap. Re-metalise the bearing. Tighten all bolts and nuts. (a) Investigate cause of system fault. (b) Arrange even loading of electrical system.
Unbalanced Phase Currents.	(1) Voltage unbalance. (2) Single phase operation. (3) Unbalance in secondary circuit.	(a) Investigate cause of system fault. (b) Arrange even loading of electrical system. <u>Repair where circuit is broken.</u> (a) Measure the resistances of rotor winding. (b) Check brazed joints between bars and short circuiting rings.
Wrong Direction of Rotation.	Reverse phase rotation due to wrong connections.	Reconnect power supply cables by interchanging any two phases at motor terminals or at inverter terminals.
Overheating of Motor	(1) Overloading	Reduce motor loading to rated load.
	(2) Increased motor current due to voltage drops.	(a) Check the voltages and increase system voltage. (b) Reduce motor loading.
	(3) Over-excitation of magnetic circuit due to high voltage.	Check the voltages and reduce system voltage.
	(4) One phase open or faulty contact	Repair where the circuit is open or faulty.
	(5) Short circuit or grounding of windings	(a) Measure the resistances and currents. (b) Repair the faulty portions.
	(6) Rubbing between stator core and rotor core.	(a) Investigate the cause by noise eg. shaft bend, damaged bearing etc. (b) Repair where faulty.
	(7) Blockage of air paths due to accumulation of dust.	Clean the ventilation passages.

TABLE 6.1 : Typical Troubles Associated with Motors, Causes and Countermeasures. (Continued)

Trouble.	Likely Causes	Countermeasure / Further Checks
Over heating of Bearings	(1) Excessive belt tension.	Reduce the belt tension.
	(2) Faulty engaging of gears of gear box.	Arrange for proper realignment of the gears.
	(3) Faulty alignment.	Make proper realignment.
	(4) Heavy vibrations.	Reduce vibrations.
	(5) Faulty installation or sinking foundation.	Adjustment /repair of foundation.
	(6) Shaft bend.	Repair / replace the shaft / rotor.
	(7) Faulty bearings.	Replace with new bearings.
	(8) Aging of grease.	Replace with fresh grease.
	(9) Inadequate grease quantity.	Put fresh grease into bearing –approx. 40 to 50 percent of the internal volume.
	(10) Heat transmission from other sources	Provide proper thermal insulation.
Vibrations	(1) Rotor unbalance.	Rebalance the rotor.
	(2) Faulty foundation.	Strengthen the foundation.
	(3) Faulty alignment.	Make proper realignment.
	(4) Unbalance in couplings.	Rebalance the couplings.
	(5) Uneven loading	Make the load balanced.
	(6) Single phase operation or unbalanced voltages.	(a) Investigate cause of open circuit and rectify. (b) Arrange evenly distributed loading of the electrical system.

TABLE 6.2. : Typical Troubles Associated with Anti-Friction Bearings, Causes and Countermeasures

Trouble	Appearances	Likely Causes	Countermeasure / Further Checks
Flaking.	<p>(a) Flaking of rolling elements.</p> <p>(b) Local flaking on raceway track.</p> <p>(c) Widespread flaking on raceway track.</p> <p>(d) Flaking on the diagonal portions of raceway track.</p> <p>(e) Widespread flaking of raceway center</p> <p>(f) Flaking across raceway track</p> <p>(g) Flaking at an interval of rolling elements pitch on raceway track</p>	<p>(1) Excessive interference.</p> <p>(2) Improper selection of bearing internal clearances.</p> <p>(3) Negative internal clearances during running.</p> <p>(4) Heat expansion.</p> <p>Ingress of foreign matter, rust, dents, etc.</p> <p>Ingress of foreign matter, rust, dents, etc.</p> <p>(1) Elliptical deformation of shaft or bearing box.</p> <p>(2) Assemblies not fully tightened.</p> <p>(3) Improper manufacturing accuracies.</p> <p>(4) Aging deformation.</p> <p>Abnormal thrust load</p> <p>(1) Shaft bend.</p> <p>(2) Inclined mounting of inner and outer bearing races.</p> <p>(1) Vibration during stoppage of motor.</p> <p>(2) Rust.</p>	<p>(a) Proper re-assembly of bearings.</p> <p>(b) Review bearing internal clearances.</p> <p>(c) Mount bearings with proper clearances.</p> <p>(d) Check operating conditions.</p> <p>Apply correct tightening forces.</p> <p>Review manufacturing accuracies.</p> <p>Review bearing design.</p> <p>Check operating conditions.</p>
Seizure of Bearings.	<p>(a) Change of colour or softening of bearing races or rolling elements.</p> <p>(b) Damage.</p>	<p>(1) Clearances -too narrow.</p> <p>(2) Poor lubrication.</p> <p>(3) Improper lubricants.</p> <p>(4) Overloads</p>	<p>(a) Check for proper clearances.</p> <p>(b) Check quantity & type of lubricants.</p> <p>(c) Check operating conditions.</p>
Crack, Splitting, Break.	<p>(a) Crack or splitting.</p> <p>(b) Break.</p>	<p>(1) Shock or growth of flaking caused due to hitting / hammering.</p> <p>(2) Excessive interference.</p> <p>Improper chamfer.</p>	<p>Careful handling during bearing assembly.</p> <p>Check interference.</p> <p>Check manufacturing accuracies of shaft and bearing box.</p>

TABLE 6.2. : Typical Troubles Associated with Anti-Friction Bearings, Causes and Countermeasures . (Continued)

Trouble	Appearances	Likely Causes	Countermeasure / Further Checks
Damage to Bearing Cage.	(a) Break. (b) Partial wear-off. (c) Wear of cage pockets. (a) Scuffing.	(1) Momentary loads. (2) Excessive high speed. (1) Poor lubrication. (2) Ingress of foreign bodies.	Careful handling and check of operating conditions. Check quantity & type of lubricants
Rust	(a) Widespread rust on bearing surfaces. (b) Partial rust (c) Contact erosion on fitting surface	(1) Poor storage. (2) Improper cleaning. (3) Use of improper anti-rust oil. (1) Insufficient packing. (2) Moisture. (1) Poor interference. (2) Fluctuating loads.	(a) Check method and place of motor storage. (b) Check anti-rust oil used. (a) Check interference. (b) Check operating conditions.
Abrasion	(a) Excessive abrasion of raceway and/or rolling elements. (b) Abrasion of cage	(1) Ingress of foreign matters into the lubricant. (2) Rust. Poor lubrication.	Check quantity and type of lubricants.
Electrical Corrosion	Craters or waving ridge marks.	Shaft current through bearing parts.	Check bearing insulation.
Indentation Bruise.	(1) Hollows. (2) Pitting. (3) Shock bruise during transportation. (4) Shock bruise during assembly.	Rolled foreign matters between raceway and rolling elements. Careless handling. Careless assembly.	Check working conditions at assembly & handling. Careful handling. Careful assembly.
Smearing	Scuffing (small seizure) on raceway and/or rolling elements.	(1) Poor lubrication. (2) Improper selection of lubricants. (3) Skewing of rolling elements.	Check lubricants and lubricating conditions.
Creep	(a) Abrasion of inside and/or outside of surface. (b) Change of color of rolling surfaces.	Insufficient interference between fittings.	(a) Check tightening forces. (b) Check manufacturing accuracies of shaft and bearing boxes. (c) Check bearing design.

6.3 SPARE PARTS

When ordering spare parts, give complete description and state the quantity of parts required, starting the drawing number if available, together with the nameplate rating, model, and serial number of the motor.

6.4 LIFTING AND DISASSEMBLING



● **Lifting by using improper lifting lug(s) can cause severe injuries, death or damages to electric motor. Lift using proper lifting lug(s) on motor as indicated in the warning labels.**

During transportation and storage etc. of the motor, it must be ensured that the motor is not stored at an inclination of more than 15 ° from the horizontal position.

Furthermore during disassembling of the motor, if the stator is placed in vertical condition, it shall be ensured that the winding connections side is on top.

6.5 SPARE PARTS LIST

TABLE 6.3. : List of Spare Parts

Item No.	Description	Applicable Motors	Specification & Quantity	Storage Precautions
1	Roller bearings as applicable.	Motors with anti-friction bearings.	Bearings numbers. One complete set for one batch of three identical motors.	Rust preventive treatment
2	Coils.	All motors.	One complete set of white coils (unimpregnated) for one batch of five identical motors.	Moisture proofing treatment
3	Filter elements.	Motors fitted with filters at air inlet.	One complete set for a batch of three identical motors.	Moisture proofing treatment
4	Sound absorbing material.	Silencer-equipped motors	One complete set for a batch of three identical motors.	Keep in a cold, dark place with moisture proofing treatment

6.6 CONSUMABLES

TABLE 6.4 shows the consumables of the three phase induction motor. It is recommended to prepare these consumables at all times. If parts other than specified below are used, inform us of such a use in advance.

TABLE 6.4. : List of Consumables

Items No.	Description	Quantity	Figure No.	Remarks
1	Ball Bearing			6220C3
2	Roller Bearing			NU220EMCM
3	Grease			Shell Alvania RL2
4	Finish Varnish			Thermosin MF-300R
5	Finish Paint			Munsell Notation 5YR6.5/14

SECTION VII

DISASSEMBLY AND ASSEMBLY

7.1 CAUTION TO BE OBSERVED DURING DISASSEMBLY AND ASSEMBLY

CAUTION

- **Observe the disassembly and assembly sequences precisely, otherwise the motor cannot be assembled completely or parts may be damaged.**
- **Select a clean and dust-free for disassembly and assembly work.**
- **Handle parts with due care so as not to damage or rust them.**
- **Observe the disassembly and assembly procedures.**
- **Observe the working conditions (temperature, pressure, grease quantity, fastening torque, etc. for example) without fail.**

7.2 REMOVAL FROM THE DRIVEN SYSTEM

For removing the machine from the driven system, see the instruction manuals issued from the driven system maker.

TABLE 7.1 : Removal from the Driven System

No.	Disassembly work	Work procedures
1	Disconnect the three phase induction motor lead wires, equalizing connector, speed sensor wires.	Particularly be careful with the handling of the connectors being connected to the three phase induction motor lead wires, equalizing connector, and speed sensor wires so as not to drop these connectors onto the floor nor strike them.
2	Draw out the joints.	For the draw-out and handling of the joints, see the instruction manual issued from the joint maker.
3	Remove the three phase induction motor from the truck.	Remove the car body mounting bolts of the three phase induction motor, and remove the three phase induction motor from the truck. Remove dust being attached to the outside of the three phase induction motor completely by means of a compressed air (about 0.29MPa) and a dry cloth after removing the machine from the truck.
4	Put the three phase induction motor on the horizontal base or floor.	

7.3 DISASSEMBLY OF THREE PHASE INDUCTION MOTOR

(1) The following table shows the work procedures up to the pull-out to the rotor during periodical inspection, etc. (See FIGURE7.1)

TABLE 7.2 : Disassembly of Three Phase Induction Motor

No.	Disassembly work	Work procedures
1	Preparations for disassembly	Prepare the following tools, instruments, agents and spare parts. (1) Crane, chain block, oil jack, special tool (e.g. puller) [for removing the coupling (or belt pulley), fan and bearing], supporting pedestals with jacks, timber racks. (2) Measuring instruments (e.g. scale, slide calipers, dial gauge, micrometer) (3) Molybdenum disulfide, non-drying sealing agent, clean oil (for bearing cleaning and heating purposes), etc. (4) Spare parts, gaskets (or packing) and other materials to be replaced.
2	Before disassembling the motor	(1) While the motor is operating, check any unusual noise, vibration and temperature. (2) Before starting work on the motor, switch off the electric power supply. Provide a safe guard to prevent the electric power from being switched on again. (3) Measure and record the circularity (true-ness) reading of both halves of the coupling and the clearance of both faces of the coupling. When necessary, remove the coupling (or belt pulley). (4) Disconnect the power supply cable and auxiliary circuit cable from the terminals within the terminal box. Measure and record the insulation resistance reading between the ground and stator winding. (5) Check the fit of the bed plate and the knock bolts, pull the knock bolts and loosen the mounting bolts. (6) If the motor cannot be disassembled at the installation place, or if it may become wet due to falling water, move the motor to an appropriate place. (7) Provide identification (match) marks across the fitting faces of stator frame (No.25) and bracket (No.19 and No.28), etc. (8) When dismantling the centered component parts (e.g. bracket), use special tools (e.g. puller). (9) Keep small parts, such as bolts, nuts, washers, etc., in containers, in order to avoid incorrect mounting. (10) Support large component parts such as the dismantled rotor-unit and brackets on timber racks such that they will not topple over or roll down.
3	Removing the bracket	First remove the bracket at the N-END (No.19) (the

		<p>bracket on the roller bearing), then remove the bracket at the D-END (No.28) (the bracket on the ball bearing).</p> <ol style="list-style-type: none"> (1) Pull out the bearing stopper (No.2) by using stud bolts, support plate and oil jack. Remove the bearing cover (outer) (No.15) at the N-END. (2) Sling with wire ropes and lift the shaft of the N-END slightly. Remove the fixing bolts of the stator frame and bracket of the N-END. (3) Lower the supporting wire ropes at the N-END of the shaft. Then gently lower the shaft and the rotor onto the inner surface of the stator core (No.24). (4) Lift the bracket with wire ropes and move it off. (5) Remove the D-END bracket as described above.
4	Removing the rotor	<ol style="list-style-type: none"> (1) Lift the shaft at both extensions and move the rotor in the axial direction for the N-END. (2) When changing the slinging positions during removal of the rotor, supporting-pedestals or jacks, and suspend the part of the rotor core (No.6) near the rotor's center of gravity with wire ropes. If it is not possible to sling the rotor's center of gravity, slip a temporary pipe onto the D-END of the shaft and move the rotor while balancing it by hand with the pipe-end.
5	Cleaning after disassembly	<p>Clean off dust which has accumulated on the following component parts.</p> <ol style="list-style-type: none"> (1) Clean the interior of the motor enclosure. If the stator winding (No.23) is excessively, dust should be blown off with clean and dry air, or wiped off with clean and dry cloth. Avoid any damage to the stator winding. (2) Check the gaskets (or packing) for deterioration. Check the noise-suppression (or absorbing) material for damage, and replace as required.

7.4 ASSEMBLY OF THREE PHASE INDUCTION MOTOR

CAUTION

- **Do not tilt the bearing bracket and bearing frame with reference to the shaft when assembling it to the shaft. Do not assemble it unreasonably. Negligence of these cautions may cause the roller bearing to be damaged.**

For assembling the machine, reverse the disassembly procedures. Check each part for wear and damage before assembling the machine, and make sure that each part is fully durable up to the next overhaul. Remove dust from each part by cleaning completely. Do not use any lock washer again, but use new one. The following tables show the reassembly work procedures.

TABLE 7.3 : Assembly the Three Phase Induction Motor

No.	Assembly work	Work procedures
1	Preparations for re-assembly	<ol style="list-style-type: none"> (1) Machining-finished faces (e.g. between stator frame and bracket) should be cleaned. (2) Component parts should be sorted according to the order of re-assembly.
2	General precautions for re-assembly	<ol style="list-style-type: none"> (1) Proceed in the reverse procedure of disassembly, when re-assembling the motor (2) Identification marks should be checked against the component parts to be re-assembled. (3) For fixing parts with bolts and nuts, use the same type of bolts and nuts as the existing ones at the time of re-assembly. Toothed washers should be replaced with new ones whenever the motor is re-assembled. Tighten securely the bolts and nuts of the rotating parts with particular care. (4) Unless otherwise specified, the tightening torque for fixing bolts and nuts should conform to TABLE 4.2 of SECTION IV, 4.3.
3	Re-assembling procedure	<ol style="list-style-type: none"> (1) Sling the rotor by both extensions of the shaft, and gently insert it into the stator-unit. (2) Apply a thin coat of grease or oil to the fitting faces of the stator frame and brackets before fastening them together. Sling the D-END bracket and set in position. Carefully align the stator frame and the bracket. Tighten the bolts fixing the bracket and stator frame. Tighten one bolt and then tighten the one directly opposite it across the bracket, until all the bolts have been tightened. (3) Mount the N-END bracket. (4) Remove the supporting-pedestals, jacks or wire ropes. (5) Mount the bearing cover (outer). (6) Heat the bearing stopper (No.2) to 160°C by induction heating or an oil bath, and mount it to shaft (No.1). Be careful not to produce any gap between the offset part of bearing (No.3) and bearing stopper (No.2).

7.5 LIST OF FIGURES

TABLE 7.4 : List of Figures

Number	Title
Table 7.5	Parts List of Three Phase Induction Motor.
Figure 7.1	Longitudinal Section of Three phase induction Motor.

**Table 7.5 Parts List of Three Phase Induction Motor
(Reference FIGURE 7.1)**

No.	Parts Name	Number of Pieces par motor	Remarks
1	Shaft	1	
2	Bearing Stopper	1	
3	Earth Brush	1set	
4	Bearing Cover (outer)	1	
5	Ball Bearing	1	6220C3 (Insulated)
6	Bearing Bracket (D-END)	1	
7	Bearing Cover	1	
8	Hex. Head Bolt	8	M16
9	Stator Coil	1set	
10	Stator Core	1set	
11	End Ring	2	
12	Rotor Clamp	2	
13	Rotor bar	38	
14	Rotor core	1set	
15	Hex. Head Bolt	8	M16
16	Bearing Bracket (N-END)	1	
17	Roller Bearing	1	NU220EMCM (Insulated)
18	Bearing Cover (outer)	1	
19	Bearing Stopper	1	
20	Bearing Cover	1	

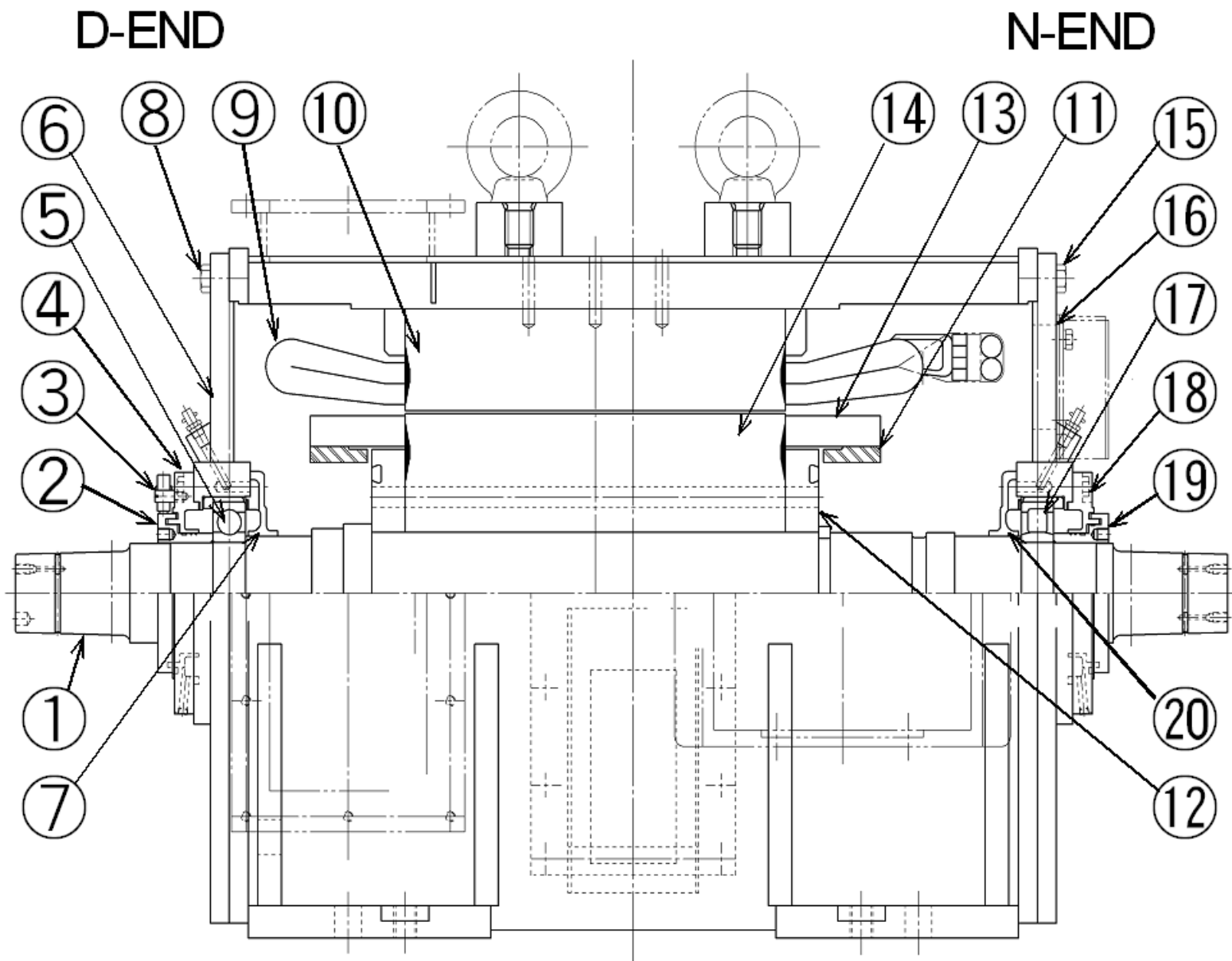

FIGURE 7.1 Longitudinal Section of Three Phase Induction Motor